

Helping Customers Innovate, Improve & Grow



Description

Vectron International's XR-R (HC35-TO5 style) cold weld crystals provide a precision, high reliability design in a rugged mount. These precision crystals offer excellent industry leading performance characteristics and tight stabilities in a wide range of frequencies. Low phase noise and low g-sensitivity options make this an ideal choice for Microwave, Satellite, Telemetry, Radar and Military Communication applications.

Features

- Industry Standard Base (2 pt, 3 pt, 4 pt blank mounts)
- Variety of package heights available
- AT, SC and IT-Cut Fundamental and OT Modes
- Low Phase Noise, Low G-Sensitivity options
- Tight Stabilities and Tolerances, Excellent Aging
- Robust Rugged Design for demanding environments
- Swept Quartz & Hi-Rel Screening Options Available
- High Temperature Options to +200°C
- MIL-PRF-3098 equivalent (CR101/U, CR102/U, CR103/U)

Applications

- Telecommunications
- Military & Defense
- Microwave
- Telemetry
- Ground and Satellite Communications
- Precision Oscillators (TCXO, VCXO, OCXO)

Standard Physical Specifications

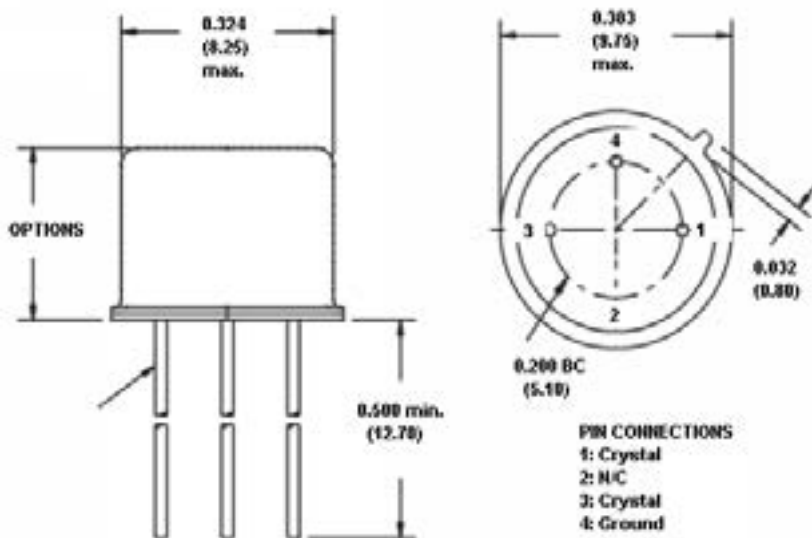

HEIGHT CODE OPTION	PACKAGE EXAMPLES	
	XR-R SERIES	
	inches	mm
1	0.265	6.73
2	0.230	5.84
3	0.200	5.08

Reference dimensions specified in inches and millimeters (mm). Specification subject to change without notice.

Typical Electrical Performance Characteristics

AT-CUT VARIETIES		
Performance Characteristic	Symbol	Typical Performance Specifications
Frequency Range	F_o	7 MHz to 225 MHz
Operating Temperature Range		-55°C to +125°C (high temperature up to +200°C available)
Frequency Stability over Operating Temp Range	F_T	+/- 5 ppm to +/- 50 ppm (mode, frequency and operating temp range dependent)
Frequency Calibration Tolerance +25°C	F_R-F_L	+/- 10 ppm typical (+/- 2 ppm available)
Equivalent Series Resistance	R (ESR)	10 ohms to 100 ohms (mode and frequency dependent)
Shunt Capacitance	C_o	2.5 pF - 4 pF typical (MIL-PRF-3098 CR101, CR102, CR103 types < 7 pF max.)
Motional Capacitance	C_1	0.1 fF - 30 fF (mode and frequency dependent)
Load Capacitance	C_L	series to 32 pF (customer specified load)
Drive Level	DL	100 uW (50 uW to 5 mW)
Aging per year after first 30 days		< 3 ppm (< 1ppm available)

DOUBLY ROTATED (DR)-CUT VARIETIES (SC, MODIFIED SC, IT, ETC...)		
Performance Characteristic	Symbol	Typical Performance Specifications
Frequency Range	F_o	7 MHz to 225 MHz
Turn Point	TP	+75°C to +105°C (mode, cut, frequency dependent, other turn points available)
Frequency Calibration Tolerance	F_R-F_L	+/- 1 ppm to +/- 5 ppm typical
Equivalent Series Resistance	R (ESR)	15 ohms to 180 ohms (mode and frequency dependent)
Shunt Capacitance	C_o	2.5 pF - 4 pF typical
Motional Capacitance	C_1	0.1 fF - 30 fF (mode and frequency dependent)
Load Capacitance	C_L	series to 32 pF (customer specified load)
Drive Level	DL	100 uW (50 uW to 5 mW)
Aging per year after first 30 days		1 ppm

PHASE NOISE @ 100 Hz OFFSET (dBc/Hz)		
Mode - Cut	Frequency Range	Phase Noise
Fundamental-AT	7 MHz -to 30 MHz	-80 to -115
Fundamental-DR		
3 rd OT - AT	17 MHz - 105 MHz	-80 to -135
3 rd OT - DR		-115 to -150
5 th OT - AT	40 MHz - 175 MHz	-90 to -135
5 th OT - DR		-115 to -140
7 th OT - AT	70 MHz - 225 MHz	-80 to -110

Phase Noise performance is mode and frequency dependent

NOMINAL G-SENSITIVITY (4 pt. blank mount)	
Cut	G-SENSITIVITY
AT	$1 \times 10^{-9}/g$ (average attainable when specified)
DR (SC-IT)	$5 \times 10^{-10}/g$ (average attainable when specified)

Results assume same frequency and mode when specified. Better results are available.

TYPICAL ESR & C_1 BY MODE AND FREQUENCY RANGE			
Mode	Frequency Range (MHz)	*ESR Typical (ohms)	* C_1 Typical (fF)
Fund.	7 - 35 MHz	25-360	5 - 25
3 rd	17 - 105 MHz	40	1 -2.5
5 th	40 - 175 MHz	75	0.70
7 th	70 - 225 MHz	120	0.35

**ESR and C_1 values are dependent upon the specified frequency and mode of vibration.*

EQUIVALENT CIRCUIT OF A CRYSTAL RESONATOR

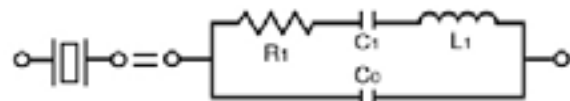

Vectron International designs and manufactures HC35 series crystals for a wide variety of commercial and high reliability applications. *Our proven cleanroom finish processes and fully integrated environmental vacuum bake cold weld systems yield excellent aging and low perturbations.*

We have tight controls over series resistance, motional capacitance, temperature characteristics and other parameters critical to your application. We primarily build to customer specifications but we've optimized designs on all frequencies that are commonly used in telecommunications.

Please feel free to contact us with your questions. We are here to assist you with selecting the best performing and most cost effective crystal for your application.

PART NUMBER ORDERING INFORMATION

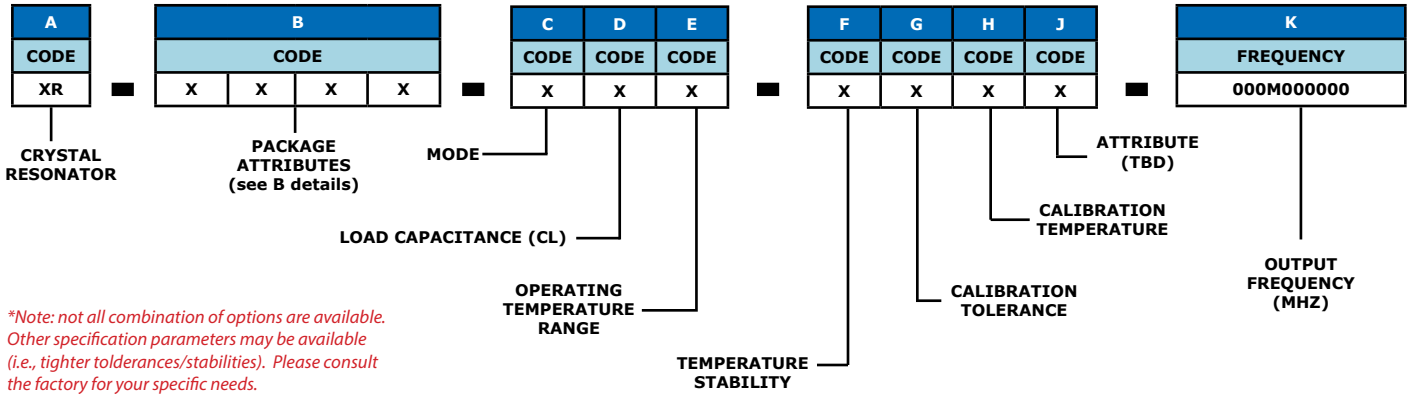

PART NUMBER CODES (attribute details)

B							
X		X		X		X	
CODE	PACKAGE TYPE	CODE	PACKAGE HEIGHT (A)	CODE	SEAL METHOD	CODE	LEAD STYLE
R	HC35	1	.265 (6.73)	1	CW	1	STANDARD
		2	.230 (5.84)			2	SOLDER DIP
		3	.200 (5.08)			3	CUT PIN 2

C		E		F		G		H		J	
CODE	MODE	CODE	OPERATING TEMPERATURE RANGE	CODE	FREQUENCY STABILITY OVER TEMPERATURE	CODE	FREQUENCY CALIBRATION TOLERANCE	CODE	FREQUENCY CALIBRATION TEMPERATURE	CODE	TBD
1	Fund	A	-55°C to +85°C	A	+/- 5 ppm	A	+/- 5 ppm	A	+25°C	A	TBD
3	3 rd OT	B	-55°C to +105°C	B	+/- 10 ppm	B	+/- 10 ppm	B	+50°C	B	TBD
5	5 th OT	C	-55°C to +125°C	C	+/- 12 ppm	C	+/- 12 ppm	C	+55°C	C	TBD
7	7 th OT	D	-40°C to +70°C	D	+/- 15 ppm	D	+/- 15 ppm	D	+60°C	D	TBD
9	9 th OT	E	-40°C to +85°C	E	+/- 20 ppm	E	+/- 20 ppm	E	+65°C	E	TBD
		F	-40°C to +105°C	F	+/- 25 ppm	F	+/- 25 ppm	F	+70°C	F	TBD
		G	-30°C to +80°C	G	+/- 30 ppm	G	+/- 30 ppm	G	+75°C	G	TBD
		H	-30°C to +85°C	H	+/- 32 ppm	H	+/- 32 ppm	H	+80°C	H	TBD
		J	-20°C to +70°C	J	+/- 40 ppm	J	+/- 40 ppm	J	+85°C	J	TBD
		K	-10°C to +60°C	K	+/- 50 ppm	K	+/- 50 ppm	K	+90°C	K	TBD
		M	-10°C to +75°C	M	+/- 60 ppm	M	+/- 60 ppm	M	+95°C	M	TBD
		N	-5°C to +70°C	N	+/- 75 ppm	N	+/- 75 ppm	N	+100°C	N	TBD
		P	0°C to +50°C	P	+/- 80 ppm	P	+/- 80 ppm	P	+105°C	P	TBD
		R	0°C to +55°C	R	+/- 90 ppm	R	+/- 90 ppm	R	+110°C	R	TBD
		S	0°C to +60°C	S	+/- 100 ppm	S	+/- 100 ppm	S	+115°C	S	TBD
		T	0°C to +70°C	T	+/- 130 ppm	T	+/- 130 ppm	T	+120°C	T	TBD
		U	0°C to +85°C	U	+/- 150 ppm	U	+/- 150 ppm	U	+125°C	U	TBD
		V	+10°C to +40°C	V	+/- 200 ppm	V	+/- 200 ppm	V	Custom	V	Custom
		W	-10°C to +70°C	W	+/- 250 ppm	W	+/- 250 ppm	CALIBRATION TEMPERATURE IS ALWAYS +25°C UNLESS OTHERWISE SPECIFIED			
		Y	-55°C to +185°C	Y	+/- 300 ppm	Y	+/- 300 ppm				
		Z	-20°C to +180°C	Z	Custom	Z	Custom				
		1	0°C to +150°C								
		2	0°C to +200°C								
		9	Custom								

Typical Environmental Specifications

TEST DESCRIPTION	SPECIFICATION REFERENCE
SHOCK	MIL-STD-202, Method 213, Cond. C (100g, 6ms, Half-Sine)
VIBRATION	MIL-STD-202, Method 201/204 (Random-Sine, 20g)
TEMPERATURE CYCLE	MIL-STD-883, Method 1010 (-55°C/+125°C), 10 cycles
THERMAL SHOCK	MIL-STD-202, Method 107
MOISTURE RESISTANCE	MIL-STD-202, Method 106
SALT ATMOSPHERE	MIL-STD-202, Method 101
ACCELERATION	MIL-STD-883, Method 2001, Condition A (5,000g)
SOLDERABILITY	MIL-STD-202, Method 208 (ANSI-EIA-J-STD-002)
TERMINAL STRENGTH	MIL-STD-202, Method 211 (2lbs)
PIND	MIL-STD-883, Method 2020, Condition A or B (20g, 10g)
FINE LEAK	MIL-STD-202, Method 112, Condition C-IIIc (1x10 ⁻⁸ atm/cc ²)
GROSS LEAK	MIL-STD-202, Method 112, Condition D
RESISTANCE TO SOLVENTS	MIL-STD-202, Method 215
RESISTANCE TO SOLDERING HEAT	MIL-STD-202, Method 210, Condition K
HIGH TEMPERATURE STORAGE	MIL-STD-883, Method 1008, Condition C (+125°C, 168 hours)
LOW TEMPERATURE STORAGE	MIL-PRF-3098

Vectron is uniquely equipped to handle all of your special test requirements. All environmental and qualification related tests are performed in house. We've demonstrated compliance and the ability to test to the requirements of all governing industry and military crystal specifications (past and present).

Some of which include;

- MIL-PRF-3098
- MIL-C-49468
- MIL-C-3098
- TOR-2006 (8583)-5236
- EEE-INST-002
- MIL-PRF-55310
- MIL-STD-202
- MIL-STD-883
- OTHERS

Additional Technical Information

Diagrams of Series and Parallel Resonant Circuits

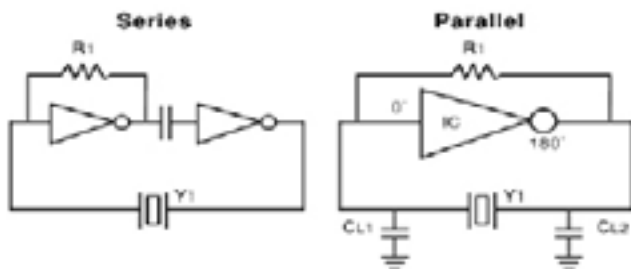

Typical Wave Solder Reflow Profile (Sn-Pb)

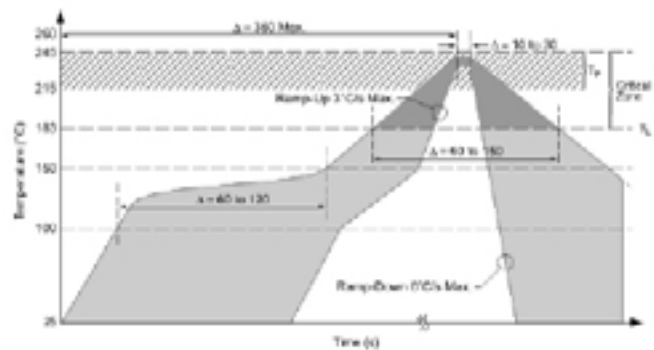

For Additional Information, Please Contact

USA:

Vectron International
4914 Gray Road
Cincinnati, OH 45232
Tel: 1.513.542.5555
Fax: 1.513.542.5146
Tel: 1.888.328.7661

Europe:

Vectron International
Landstrasse, D-74924
Neckarbischofsheim, Germany
Tel: +49 (0) 3328.4784.17
Fax: +49 (0) 3328.4784.30

Asia:

Vectron International
1F-2F, No 8 Workshop, No 308 Fenju Road
WaiGaoQiao Free Trade Zone
Pudong, Shanghai, China 200131
Tel: 86.21.5048.0777
Fax: 86.21.5048.1881

Disclaimer

Vectron International reserves the right to make changes to the product(s) and or information contained herein without notice. No liability is assumed as a result of their use or application. No rights under any patent accompany the sale of any such product(s) or information.

Rev: 12/2009